

TORQUE SETTINGS

NO.	DESCRIPTION	Nm	Ft/Lb
<i>*Use a temporary thread retainer such as LocTite #609</i>			
Items #3, #4, #5 are OEM bolts not included in MooreSport Subframes			
1*	m12 Tube Nut - diff mount to differential	70	52
2*	m12 Cap Screw - diff mount to frame	70	52
3	OEM rear lateral link bolt (not supplied in kit)	100	74
4	OEM forward lateral link bolt (not supplied in kit)	100	74
5	OEM frame to chassis bolt (not supplied in kit)	130	96

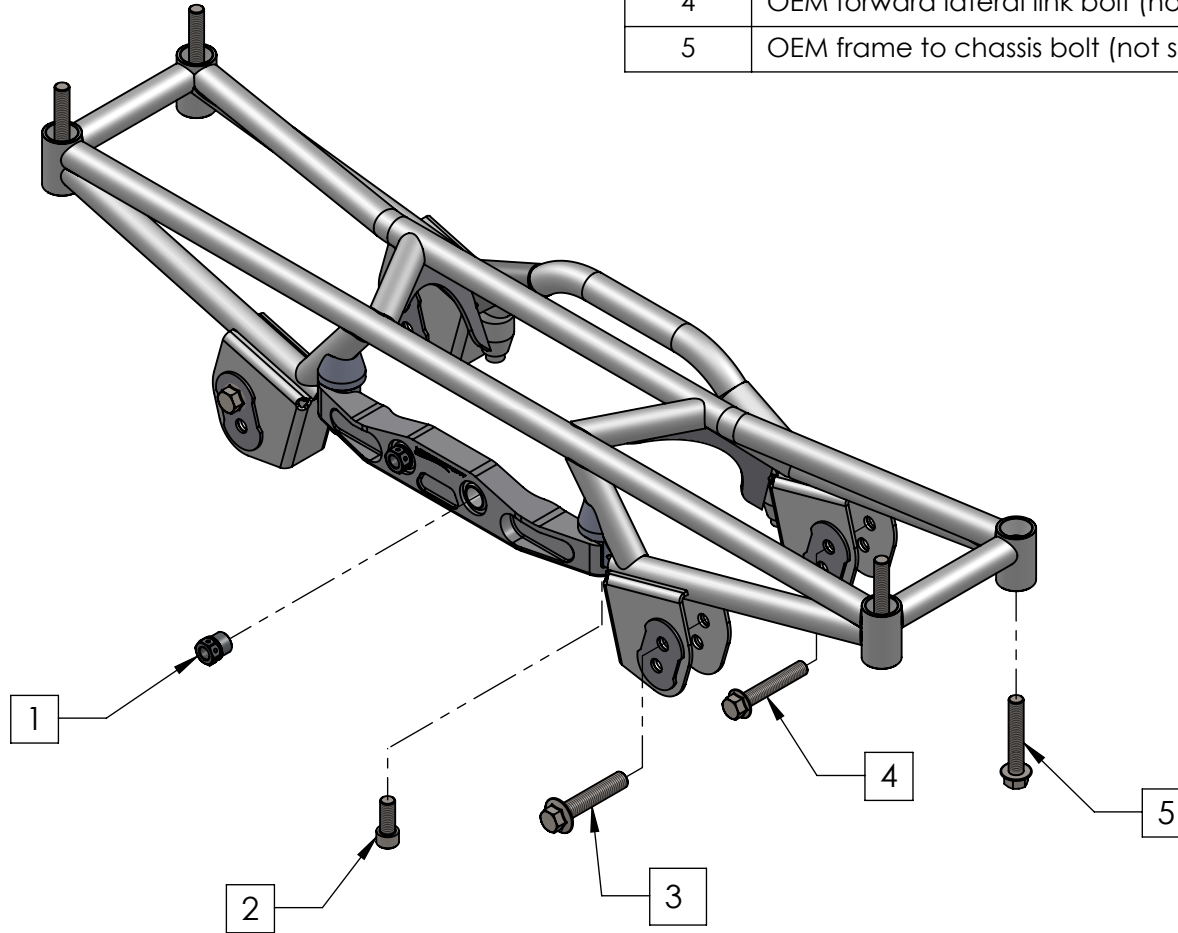

THE INFORMATION CONTAINED IN THIS DRAWING IS THE SOLE PROPERTY OF MSI (Moore-Sport INC.). ANY REPRODUCTION IN PART OR AS A WHOLE IS STRICTLY PROHIBITED.

Gravel Rear Subframe Assembly



CAR MODEL	Impreza GC/GD	CONFIGURATION:	Default	ASSEMBLY:	MSIsub05-28-003	REV	1	2023-11-30
APPLICATION	Motorsport ONLY							8279.09