

# INSTALLATION INSTRUCTIONS

NO.	DESCRIPTION	Nm	Ft/Lb
<i>Use a temporary thread retainer such as Loctite #609</i>			
1	m12 Tube Nut to shock pin	47	34
2	m8 Flange Bolt to mounting plate	18	13
3	m6 aduster plate lock bolt	7	5

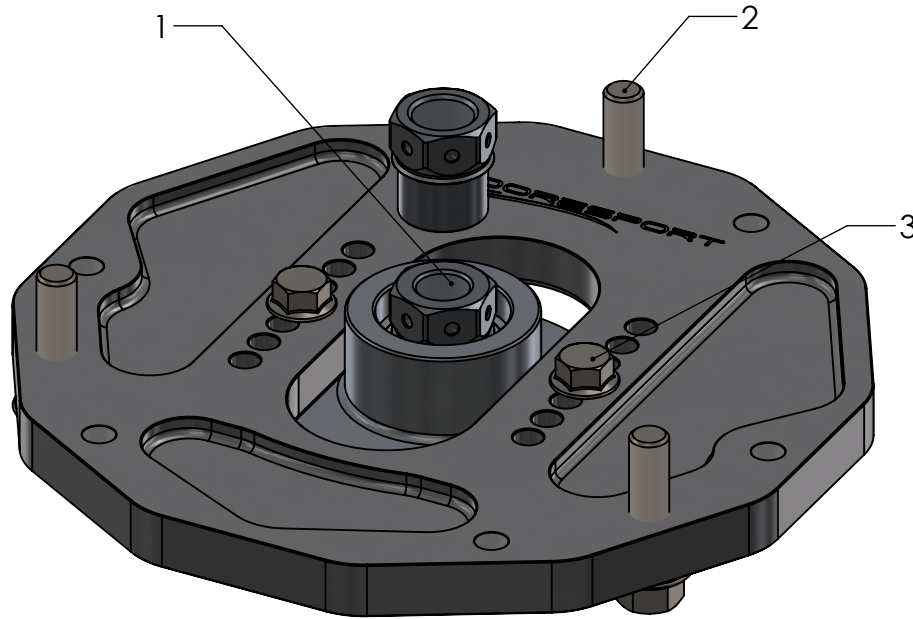

THE INFORMATION CONTAINED IN THIS DRAWING IS THE SOLE PROPERTY OF MSI (Moore-Sport INC.). ANY REPRODUCTION IN PART OR AS A WHOLE IS STRICTLY PROHIBITED.



## GR Front Street Camber Plate

CAR MODEL	GR	CONFIGURATION:	ASSEMBLY:	REV	2021-12-15
APPLICATION	Street	<b>Default</b>	<b>MSIsub02-19-001</b>	<b>1</b>	1602.68

# INSTALLATION INSTRUCTIONS

POSITION	USE
1	RH Camber/Caster
2	RH/LH Camber Only
3	LH Camber/caster

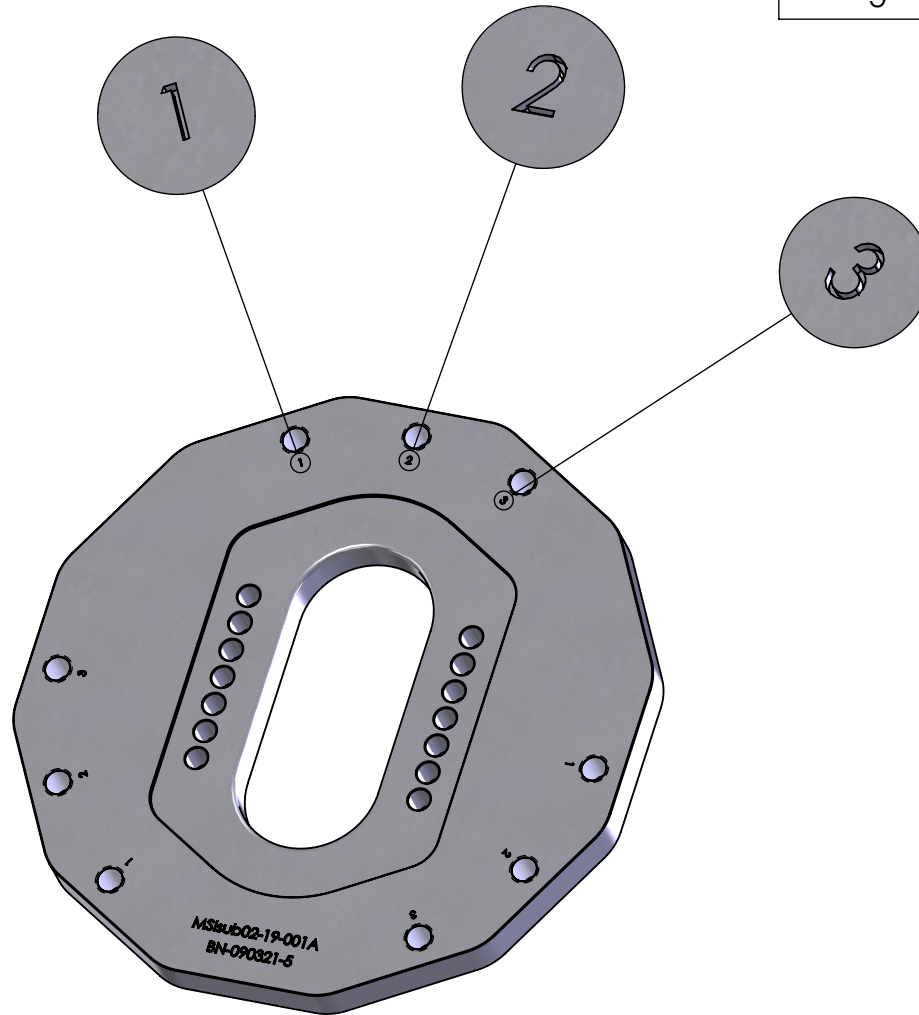

THE INFORMATION CONTAINED IN THIS DRAWING IS THE SOLE PROPERTY OF MSI (Moore-Sport INC). ANY REPRODUCTION IN PART OR AS A WHOLE IS STRICTLY PROHIBITED.

## Front GR Top Mount Base



CAR MODEL	GR	CONFIGURATION:	ASSEMBLY:	REV	2021-03-22
APPLICATION	Street / Motorsport	<b>MSIsub02-19-001a</b>	<b>MSIsub02-19-001A</b>	<b>5</b>	535.908